

Insertion Guide For The Akreos™ Single Use Insertion Device

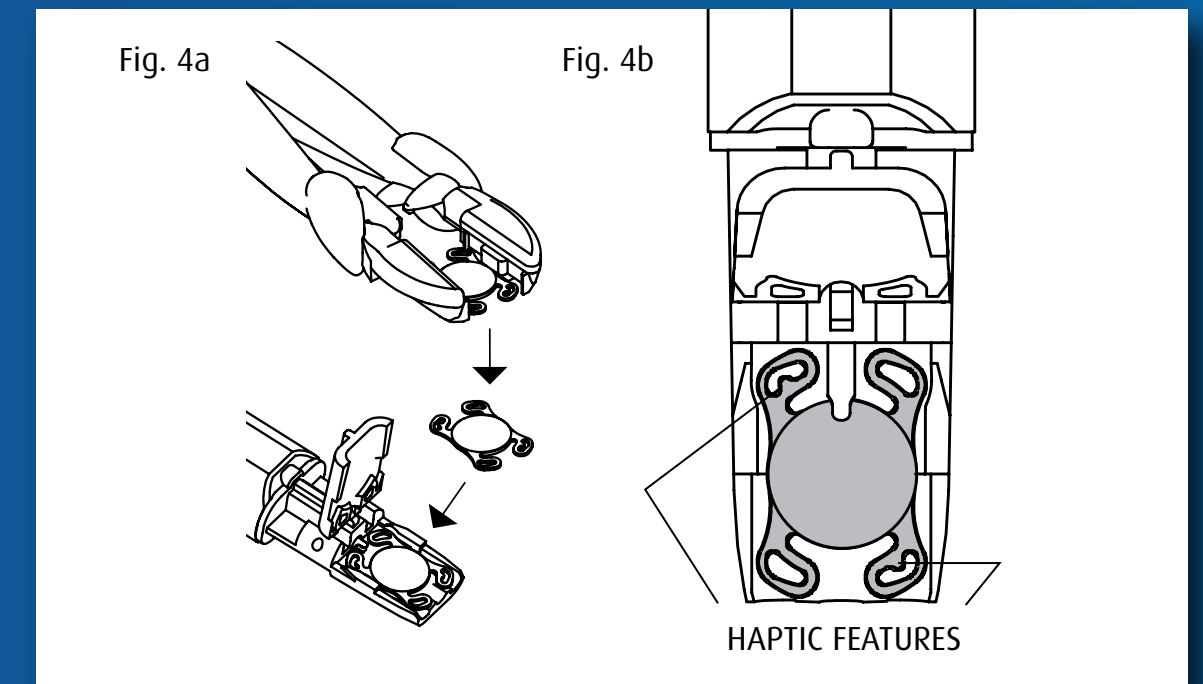
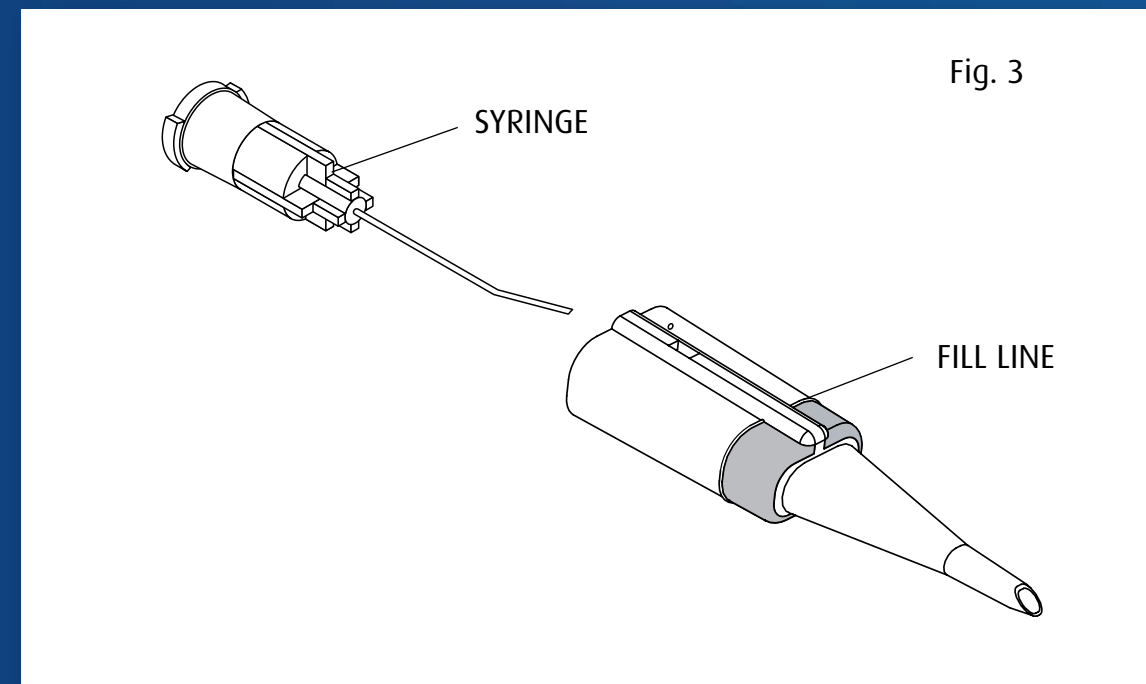
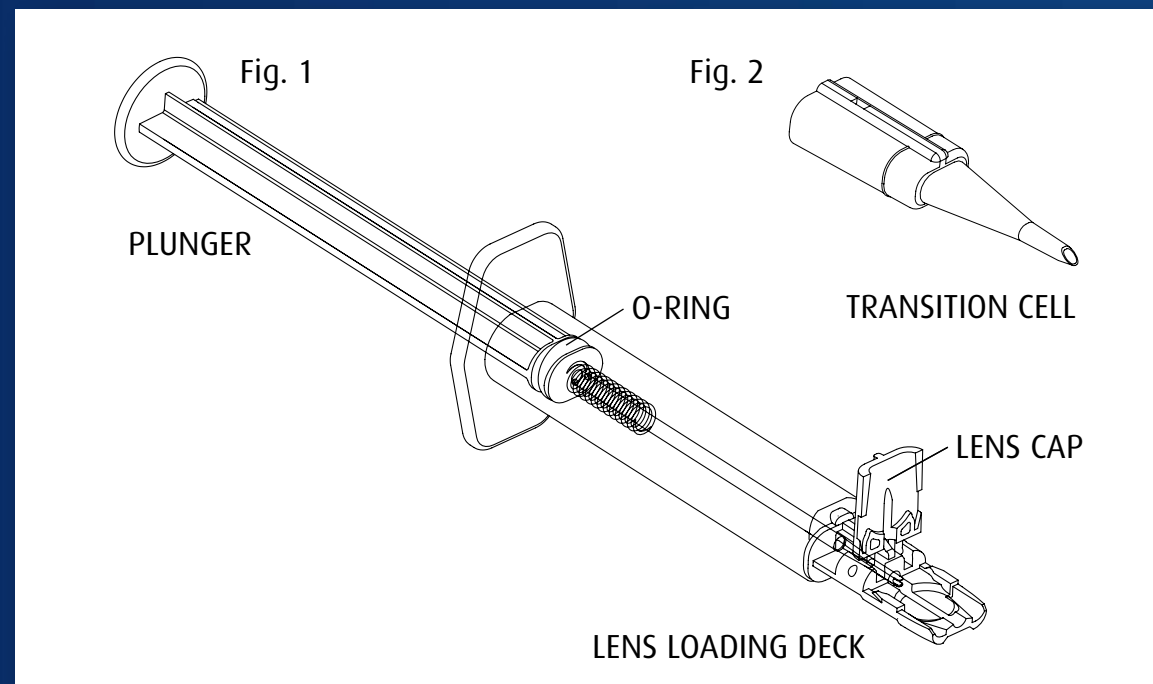

DESCRIPTION

The Akreos Single Use Insertion Device is used for folding and delivering the Bausch & Lomb one-piece Akreos Advanced Optics Aspheric Lens into the eye.

INSTRUCTIONS FOR USE

1. Open the package using standard sterile procedures. Place contents onto the sterile field.
2. Fill the rectangular end of the transition cell with viscoelastic as shown in Fig. 3, using the line as a guide.

3. Select the syringe-shaped body and plunger. Pull the plunger until the tip of the plunger is just visible in the lens loading deck. Place a drop of viscoelastic directly in the center of the loading deck. Open the vial and remove the lens holder. Position the lens holder with its jaws facing down (Fig. 4a). With a blunt, non-toothed forceps, remove the lens from the lens holder by pulling the lens down. Transfer the lens to the recessed area in the injector loading deck (Fig. 4a), ensuring that the lens is not flipped during the transfer. The lens is loaded in correct orientation if its haptic features are as shown in Fig. 4b.
4. Advance the plunger until the fork fully captures the lens edge. Place a drop of viscoelastic in the center of the lens. Verify that the lens is inside the recessed area of the loading deck, prior to closing the lens cap.

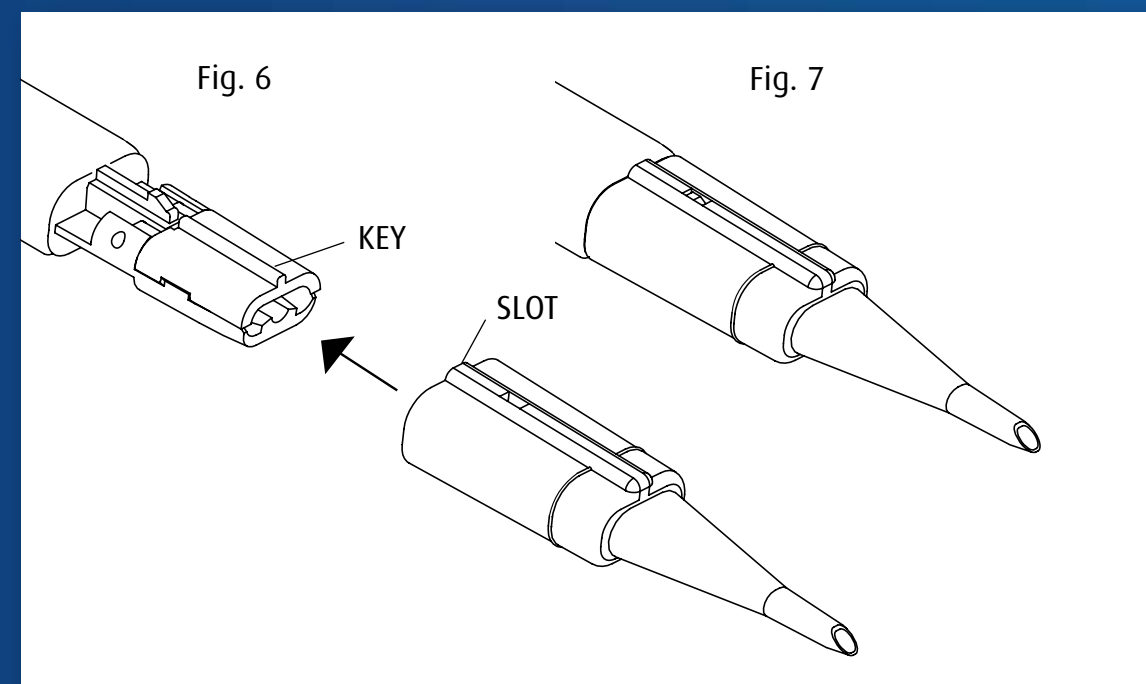
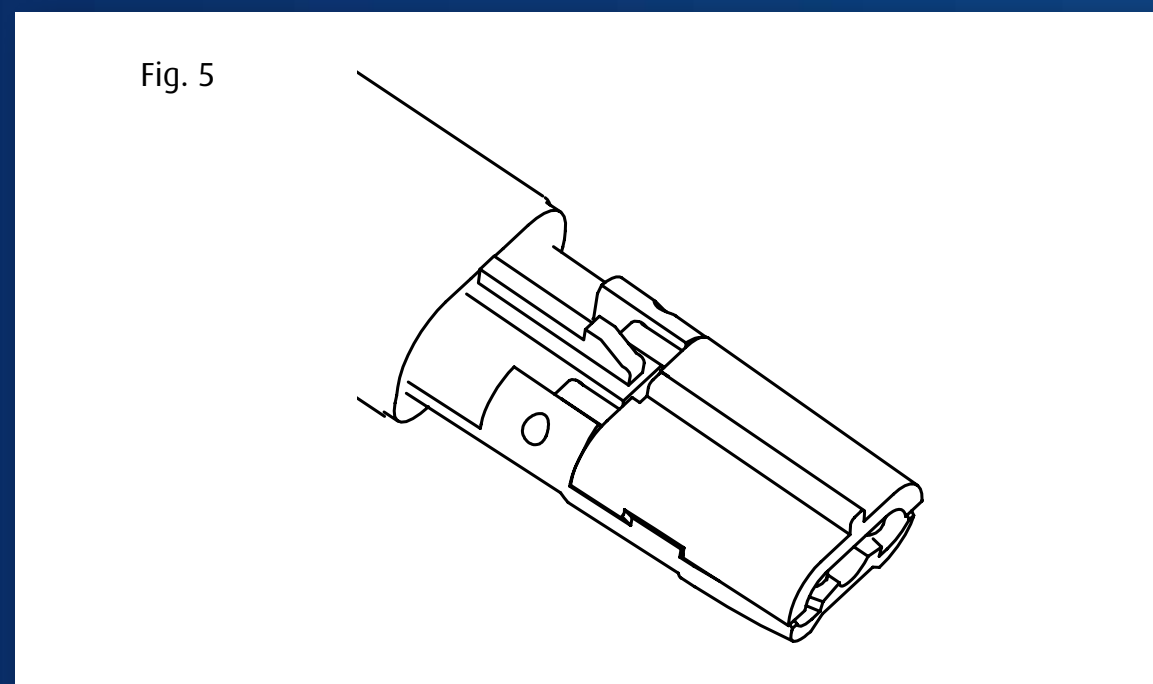

5. Close the lens cap (Fig. 5).
6. Align the key on the lens cap with the slot in the transition cell (Fig. 6). Push together with a firm motion until the body with the cap and transition cell snap together (Fig. 7). Once assembled, pull on the transition cell to verify that it cannot be separated from the body.
7. Fill the tip of the transition cell with viscoelastic material or balanced salt solution to eliminate air pockets.

IMPORTANT! TO AVOID POTENTIAL LENS DAMAGE

8. The lens is now ready to be delivered. Turn the device over, so that the bevel is face down, and insert the beveled portion of the transition cell through the incision in the eye. When the tip is positioned, apply continuous uniform forward motion to the plunger. A slow smooth forward motion of the plunger is essential for proper transition of the lens into the folded delivery position. Reverse movement of the plunger may result in the loss of control of the lens and/or damage to the lens. Continue the forward motion until the leading haptics and optic are fully expressed from the tip. Pausing delivery, prior to the optic clearing the tip, may cause damage to the lens.
9. When the leading haptics and optic completely clear the transition cell tip, release pressure on the plunger. This allows the spring action of the plunger to completely retract the plunger fork into the transition cell. Push the plunger forward again to engage the trailing haptics and complete the lens delivery into the eye.

